

— MODEL — **CRD40**

Pressure Reducing Control

Description

The CRD40 Pressure Reducing Control automatically reduces a higher inlet pressure to a lower outlet pressure. It is a direct acting, spring loaded, diaphragm type control that operates hydraulically. It is used as a pilot control with Cla-Val automatic control valves to hold a constant downstream pressure. Cla-Val Model CRD40 maximum inlet pressure rating: 400 psi

Installation and Adjustment

Before installing the CRD40 Pressure Reducing Control, flush out line to remove loose dirt and scale which might damage seal ring and seat. Install control in-line with arrow on valve body pointing in direction of flow. The CRD40 may be installed in any position.

The standard adjustment range is 15 to 150 psi with a factory setting of 50 psi. To readjust outlet pressure, loosen lock nut and turn adjustment bolt clockwise (into bell housing) to raise outlet pressure. To lower outlet pressure setting turn adjustment bolt counterclockwise (out of bell housing).

Caution: A pressure gauge must be used downstream to verify correct pressure setting. Do not bottom out adjustment bolt on bell housing.

Notice: To ensure proper performance and maximum service life for the CRD40, it is suggested that a program of regular inspection, testing, maintenance and cleaning be utilized. Annual inspection and maintenance is recommended.

Disassembly

1. Before starting disassembly remove line pressure from control.
2. Measure distance adjustment bolt protrudes from bell housing. Loosen lock nut on adjustment bolt and turn adjustment bolt out of bell housing only to remove spring tension. **DO NOT REMOVE ADJUSTMENT BOLT, SPACER OR lock nut FROM BELL HOUSING.**
3. Unscrew bell housing counterclockwise and remove spring, spring disc and friction ring.
4. Remove cartridge assembly from valve body by gripping retaining bolt with pliers and pulling outward away from valve body.

Reassembly

1. If possible, flush any debris out of valve body by allowing some water flow while CRD40 is apart.
2. Replace old cartridge assembly with new cartridge assembly. Carefully push new cartridge assembly into body making sure O-rings seal tight against both cartridge and body. A small amount of waterproof grease on O-rings may help cartridge assembly slip into place.
3. Replace friction ring, spring, spring disc and bell housing with adjustment bolt in place in order shown on drawing. Friction ring must be installed as shown in diagram to avoid damage.
4. Turn adjustment bolt into bell housing to original measured setting.
5. After remaining components of control valve pilot system and main valve are serviced, recheck pressure setting of CRD40 with flow through the valve. To readjust outlet pressure, loosen outer lock nut and turn adjustment bolt clockwise (into bell housing) to raise outlet pressure setting, turn adjustment bolt counterclockwise (out of bell housing) to lower outlet pressure setting.

Troubleshooting

Symptom	Probable Cause	Remedy
Fails to close when outlet pressure rises	Foreign matter on seating face of seal O-ring	Disassemble and remove
	Cartridge assembly damaged	Disassemble and replace
	Cut or worn stem O-ring or worn O-ring groove	Replace cartridge assembly
	Spring compressed solid	Loosen adjustment bolt
Fails to open when outlet pressure lowers	Cartridge assembly damaged	Disassemble and replace
	No spring compression	Tighten adjustment bolt
	Damaged spring	Disassemble and replace

1/2" & 3/4" CRD40 Repair Kit Part Number 20348406K



1/2" CRD-40 Pressure Reducing Control Valve

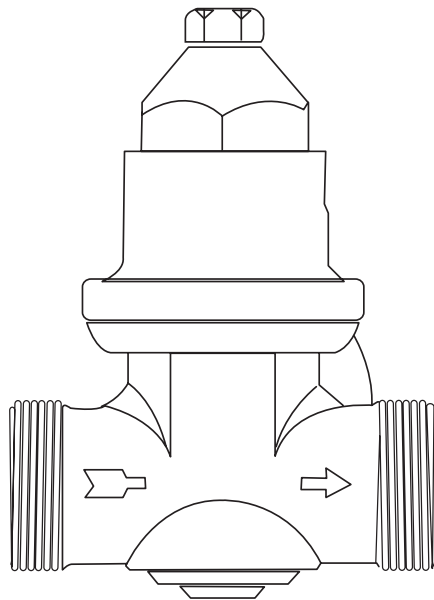
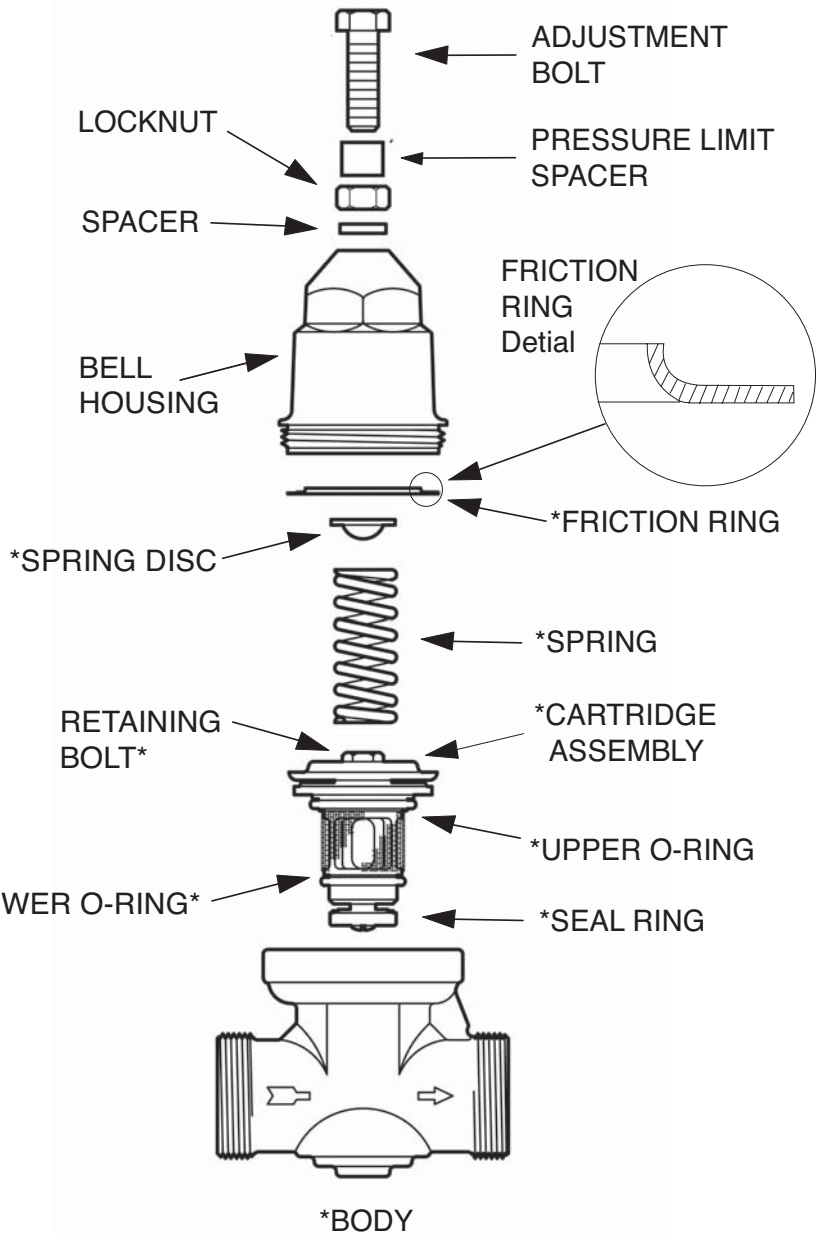

Sizes: 1/2" - 3/4"

*Indicates Parts Supplied in CRD40 Repair Kit P/N 20348406K

FLOW CHARACTERISTICS
MODEL CRD40 1/2" & 3/4" (STANDARD & METRIC)

